

REINHOLD ENVIRONMENTAL Ltd.



**2012 Coal to Gas Conversion Round Table
& Expo Presentation**

October 23, 2012, Chattanooga, TN / Sponsored by TVA

All presentations posted on this website are copyrighted by Reinhold Environmental, Ltd (RE). Any unauthorized downloading, attempts to modify or to incorporate into other presentations, link to other websites, or obtain copies for any other uses than the training of attendees to RE's Conferences is expressly prohibited, unless approved in writing by RE or the original presenter. RE does not assume any liability for the accuracy or contents of any materials contained in this library which were presented and/or created by persons who were not employees of RE.



thebabcock&wilcoxcompany

Coal to Gas Conversion

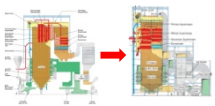

Don Ryan
Division Mgr, BWSC Engineering

Gas Conversion Fundamentals

So you want to
Convert this...

Into

This?

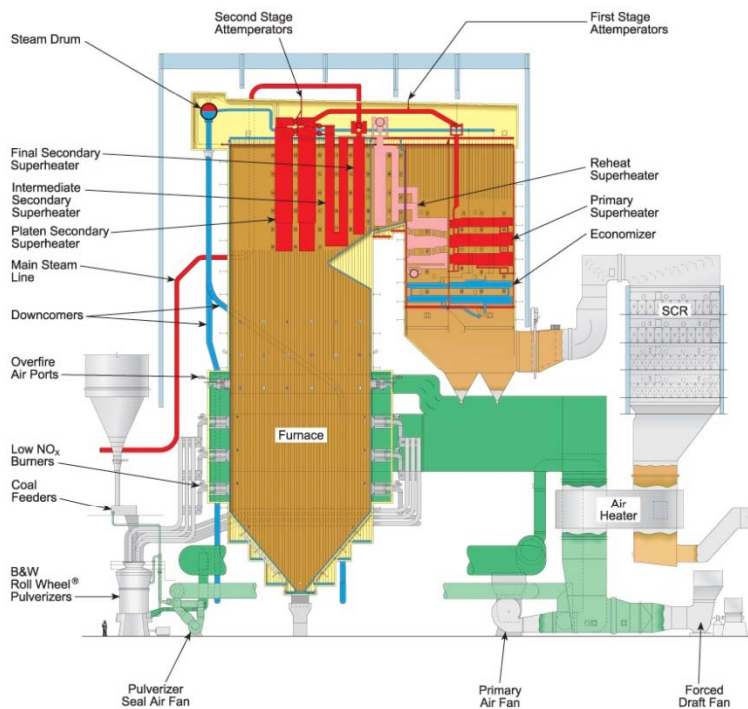

Typical PC Boiler

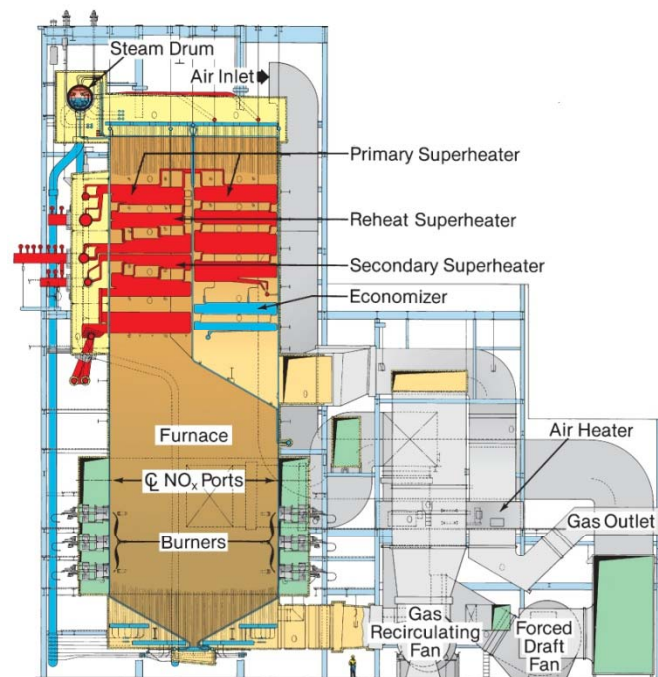

Typical Gas Boiler

Gas Conversion Fundamentals

Typical Fuel Analysis Comparison

Proximate (% by wt)	Bituminous	PRB	Natural Gas	
Moisture	3.5	27.22	90.0	CH ₃ (% by vol)
Volatile	35.7	29.90	5.0	C ₂ H ₆ (% by vol)
Fixed Carbon	51.8	37.17	5.0	N ₂ (% by vol)
Ash	9.0	5.71		
Ultimate (% by wt)				
Carbon	72.8	49.99	69.20	
Hydrogen	4.8	3.62	22.65	
Sulfur	2.2	0.33		
Oxygen	6.2	12.43		
Nitrogen	1.5	0.70	8.08	
Moisture	3.5	27.22		
Ash	9.0	5.71		
HHV (btu/lb)	13080	8772	21800	

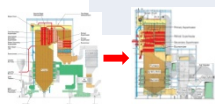

Gas Conversion Fundamentals

Typical Flue Gas Property Comparison

@ constant excess air

% by wt.	Bituminous	PRB	Natural Gas
O ₂	2.92	2.80	2.98
CO ₂	21.34	21.42	13.01
N	70.48	67.59	72.41
H ₂ O	4.91	8.12	11.60
SO ₂	0.35	0.07	0.00
Specific Heat	0.272	0.278	0.286

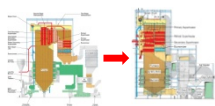

Gas Conversion Fundamentals

Typical Efficiency Comparison

(Constant X-Air and AH Outlet Temps)

	Bituminous	PRB	Natural Gas
Losses (%)			
Dry Gas	4.82	4.78	4.20
Water from Fuel	4.07	7.83	10.62
Moist in Air	0.11	0.11	0.11
Unburned Combustible	0.30	0.15	0
Radiation	0.17	0.17	0.17
Unaccounted For	1.50	1.50	1.00
Total Losses	10.97	14.54	16.10
Boiler Efficiency	89.03	85.46	83.9

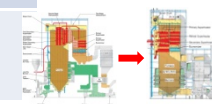

Gas Conversion Fundamentals

Other Performance Parameters

	Bituminous	PRB	Natural Gas
Fuel Input	Base	1.05x	1.08x
Air Wt.	Base	1.04x	0.98x
Gas Wt.	Base	1.08x	0.96x
FEGT	Base	+50-100F	+30F
Surface Effectiveness			
Furnace	Base	Base	1.08x
Convection	Base	(.8-.95)x	1.2x

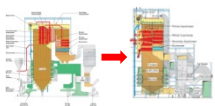

Coal to NG Conversion Equipment Boiler Considerations

Two Design Approaches for Steam Temperature Control:



Coal to NG Conversion Equipment Boiler Considerations

Two Design Approaches for Steam Temperature Control:

- Wall Firing, Fixed Burners – B&W, FW, Babcock Power (Riley)



Coal to NG Conversion Equipment Boiler Considerations

Two Design Approaches for Steam Temperature Control:

- Wall Firing, Fixed Burners – B&W, FW, Babcock Power (Riley)
- Corner Firing, Tilting Burners – Alstom (CE)



Coal to NG Conversion Equipment Boiler Considerations

Two Design Approaches for Steam Temperature Control:

- Wall Firing, Fixed Burners – B&W, FW, Babcock Power (Riley)
 - Steam Temperature Controlled by:
 - Attemperation
- Corner Firing, Tilting Burners – Alstom (CE)



Coal to NG Conversion Equipment Boiler Considerations

Two Design Approaches for Steam Temperature Control:

- Wall Firing, Fixed Burners – B&W, FW, Babcock Power (Riley)
 - Steam Temperature Controlled by:
 - Attemperation
 - Gas Biasing (parallel downpass)
- Corner Firing, Tilting Burners – Alstom (CE)



Coal to NG Conversion Equipment Boiler Considerations

Two Design Approaches for Steam Temperature Control:

- Wall Firing, Fixed Burners – B&W, FW, Babcock Power (Riley)
 - Steam Temperature Controlled by:
 - Attemperation
 - Gas Biasing (parallel downpass)
 - Excess Air
- Corner Firing, Tilting Burners – Alstom (CE)



Coal to NG Conversion Equipment Boiler Considerations

Two Design Approaches for Steam Temperature Control:

- Wall Firing, Fixed Burners – B&W, FW, Babcock Power (Riley)
 - Steam Temperature Controlled by:
 - Attemperation
 - Gas Biasing (parallel downpass)
 - Excess Air
 - Gas Recirculation
- Corner Firing, Tilting Burners – Alstom (CE)



Coal to NG Conversion Equipment Boiler Considerations

Two Design Approaches for Steam Temperature Control:

- Wall Firing, Fixed Burners – B&W, FW, Babcock Power (Riley)
 - Steam Temperature Controlled by:
 - Attemperation
 - Gas Biasing (parallel downpass)
 - Excess Air
 - Gas Recirculation
- Corner Firing, Tilting Burners – Alstom (CE)
 - Steam Temperature Controlled by:
 - Burner Tilts



Coal to NG Conversion Equipment Boiler Considerations

Two Design Approaches for Steam Temperature Control:

- Wall Firing, Fixed Burners – B&W, FW, Babcock Power (Riley)
 - Steam Temperature Controlled by:
 - Attemperation
 - Gas Biasing (parallel downpass)
 - Excess Air
 - Gas Recirculation
- Corner Firing, Tilting Burners – Alstom (CE)
 - Steam Temperature Controlled by:
 - Burner Tilts
 - Attemperartion



Coal to NG Conversion Equipment Boiler Considerations

Two Design Approaches for Steam Temperature Control:

- Wall Firing, Fixed Burners – B&W, FW, Babcock Power (Riley)
 - Steam Temperature Controlled by:
 - Attemperation
 - Gas Biasing (parallel downpass)
 - Excess Air
 - Gas Recirculation
- Corner Firing, Tilting Burners – Alstom (CE)
 - Steam Temperature Controlled by:
 - Burner Tilts
 - Attemperartion
 - Gas Recirculation



Coal to NG Conversion Equipment Boiler Considerations

Pressure Parts:

- ▶ Radiant SH & RH surface absorptions are lower due to flue gas properties

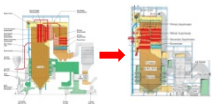

Coal to NG Conversion Equipment Boiler Considerations

Pressure Parts:

- ▶ Radiant SH & RH surface absorptions are lower due to flue gas properties
- ▶ Convective surface absorptions are higher due to gas weight, gas properties and surface effectiveness

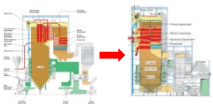

Coal to NG Conversion Equipment Boiler Considerations

Pressure Parts:

- ▶ Radiant SH & RH surface absorptions are lower due to flue gas properties
- ▶ Convective surface absorptions are higher due to gas weight, gas properties and surface effectiveness
- ▶ Spray attemperator capacities need to be checked

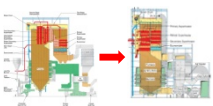

Coal to NG Conversion Equipment Boiler Considerations

Pressure Parts:

- ▶ Radiant SH & RH surface absorptions are lower due to flue gas properties
- ▶ Convective surface absorptions are higher due to gas weight, gas properties and surface effectiveness
- ▶ Spray attemperator capacities need to be checked
- ▶ PSH, SSH and RH outlet sections often require surface adjustments and/or materials upgrades

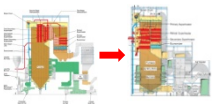

Coal to NG Conversion Equipment Boiler Considerations

Pressure Parts:

- ▶ Radiant SH & RH surface absorptions are lower due to flue gas properties
- ▶ Convective surface absorptions are higher due to gas weight, gas properties and surface effectiveness
- ▶ Spray attemperator capacities need to be checked
- ▶ PSH, SSH and RH outlet sections often require surface adjustments and/or materials upgrades
- ▶ PSH outlet headers sometimes need to be upgraded

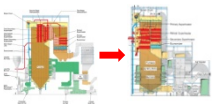

Coal to NG Conversion Equipment Boiler Considerations

Pressure Parts:

- ▶ Radiant SH & RH surface absorptions are lower due to flue gas properties
- ▶ Convective surface absorptions are higher due to gas weight, gas properties and surface effectiveness
- ▶ Spray attemperator capacities need to be checked
- ▶ PSH, SSH and RH outlet sections often require surface adjustments and/or materials upgrades
- ▶ PSH outlet headers sometimes need to be upgraded
- ▶ Economizer surface may need to be modified to prevent steaming

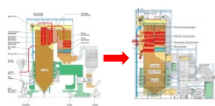

Coal to NG Conversion Air System Considerations

There are several configurations of Primary/Secondary Air Systems

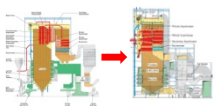

Coal to NG Conversion Air System Considerations

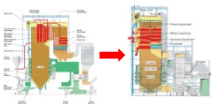
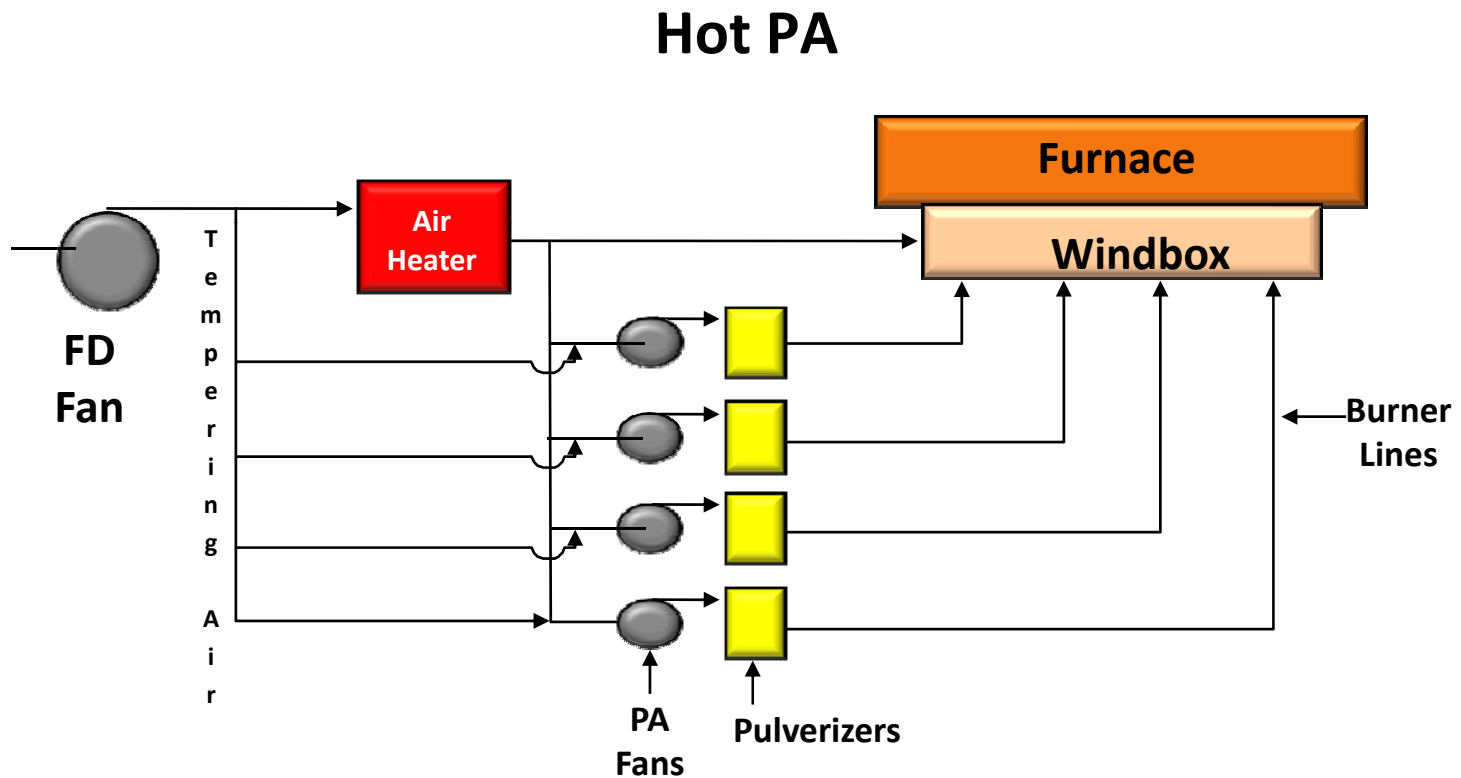

Coal to NG Conversion Air System Considerations

Hot PA After Conversion

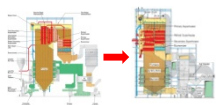
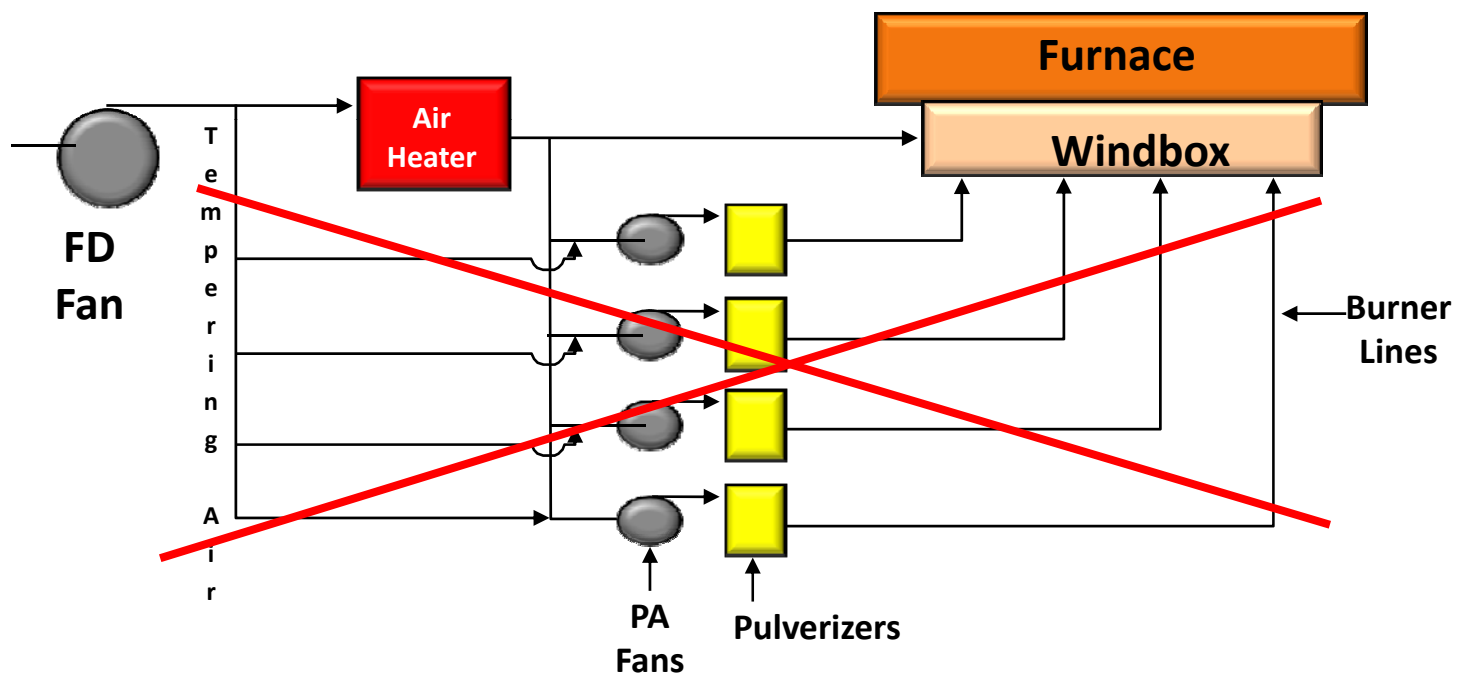

Coal to NG Conversion Air System Considerations

Cold PA

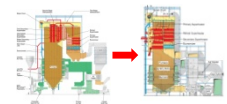
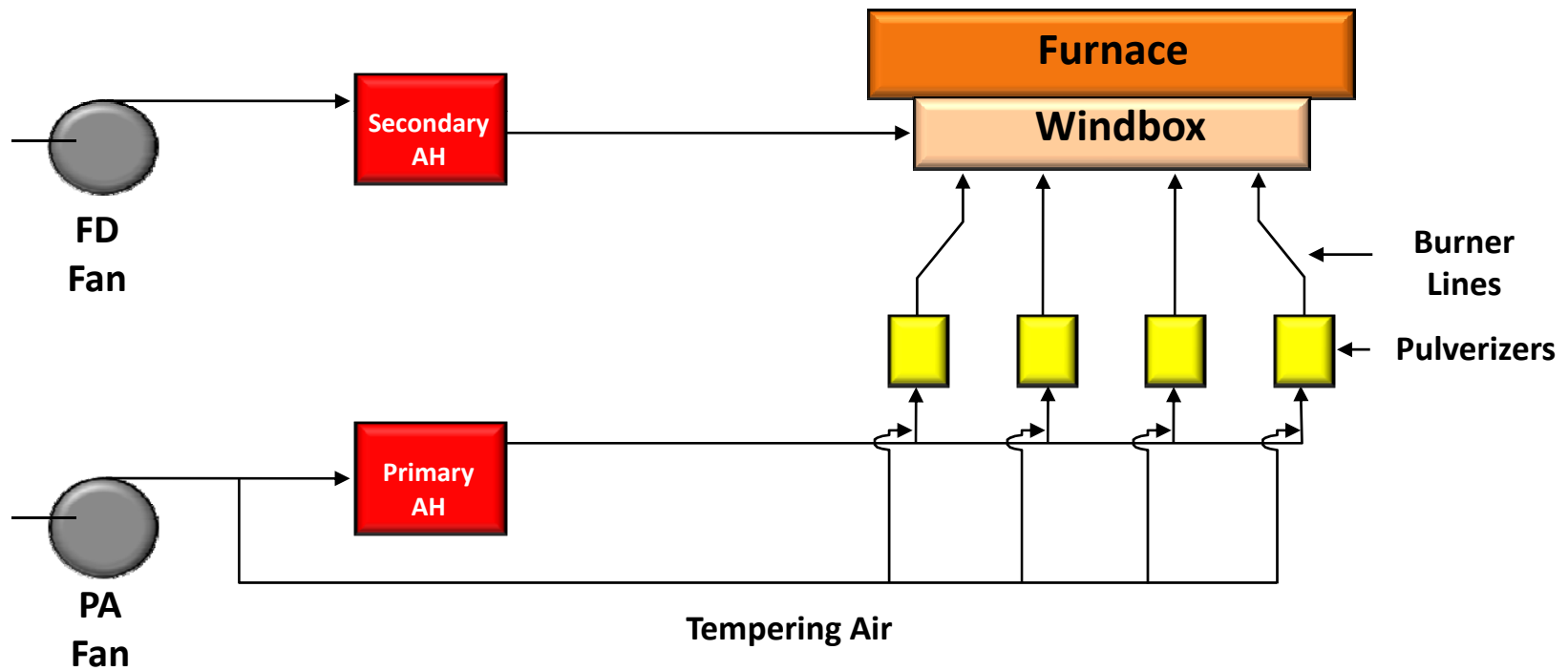

Coal to NG Conversion Air System Considerations

Cold PA After Conversion

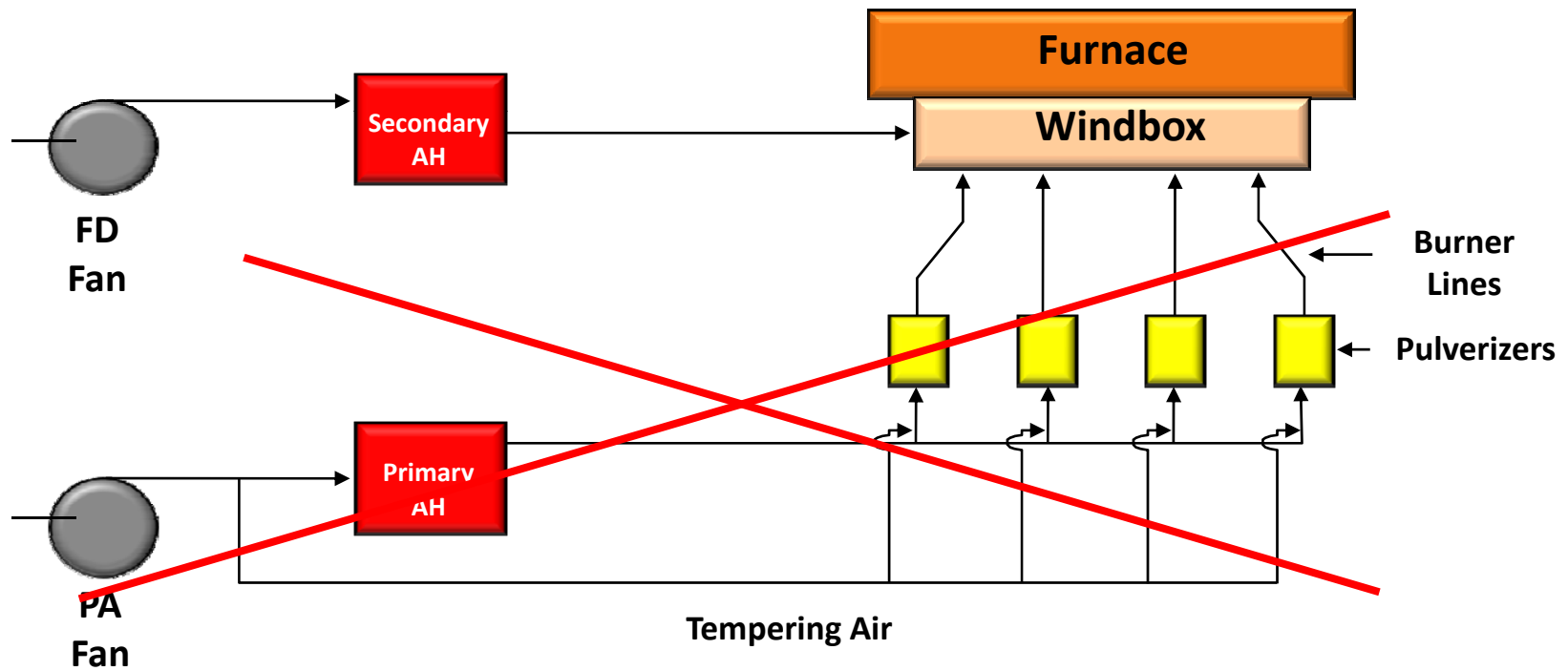

Coal to NG Conversion Air System Considerations

Boosted PA

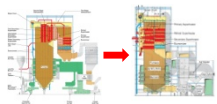
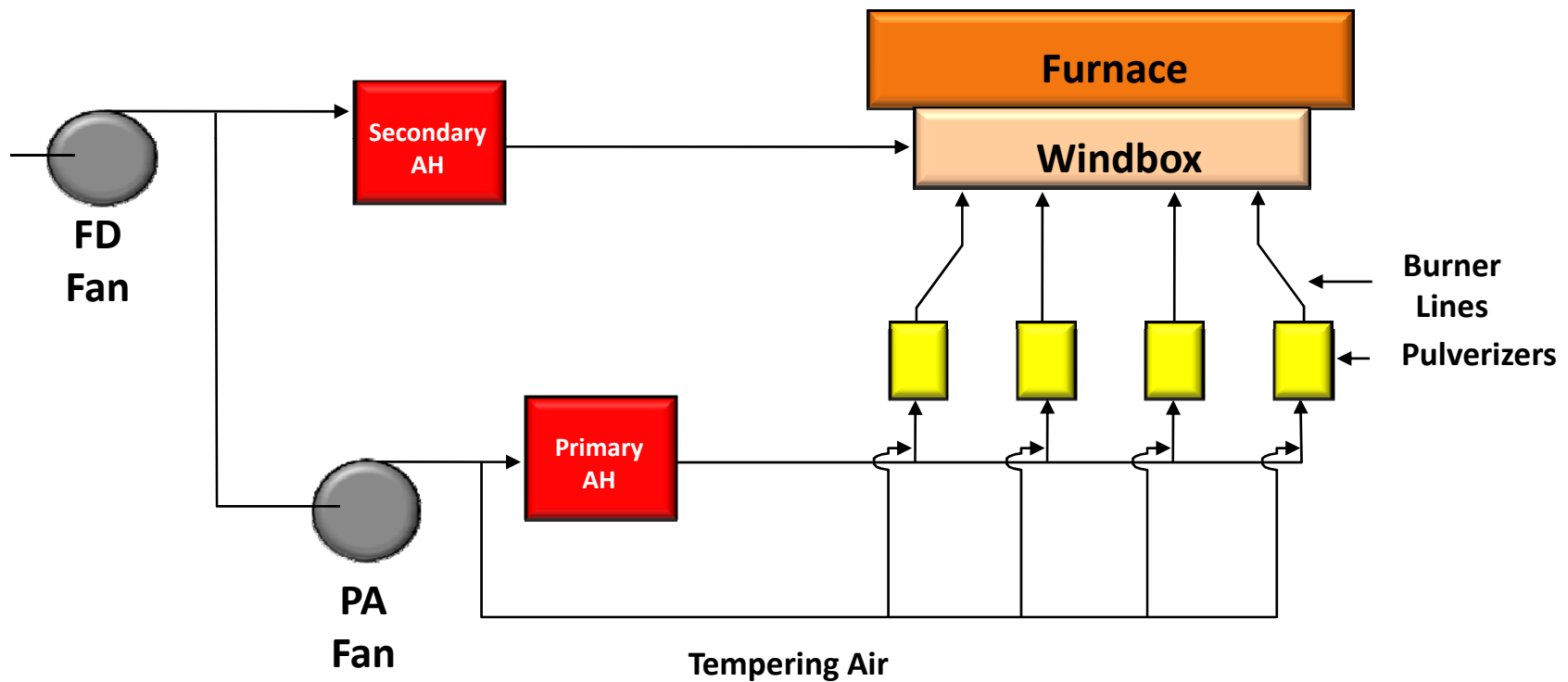

Coal to NG Conversion Air System Considerations

Boosted PA After Conversion

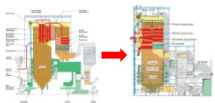
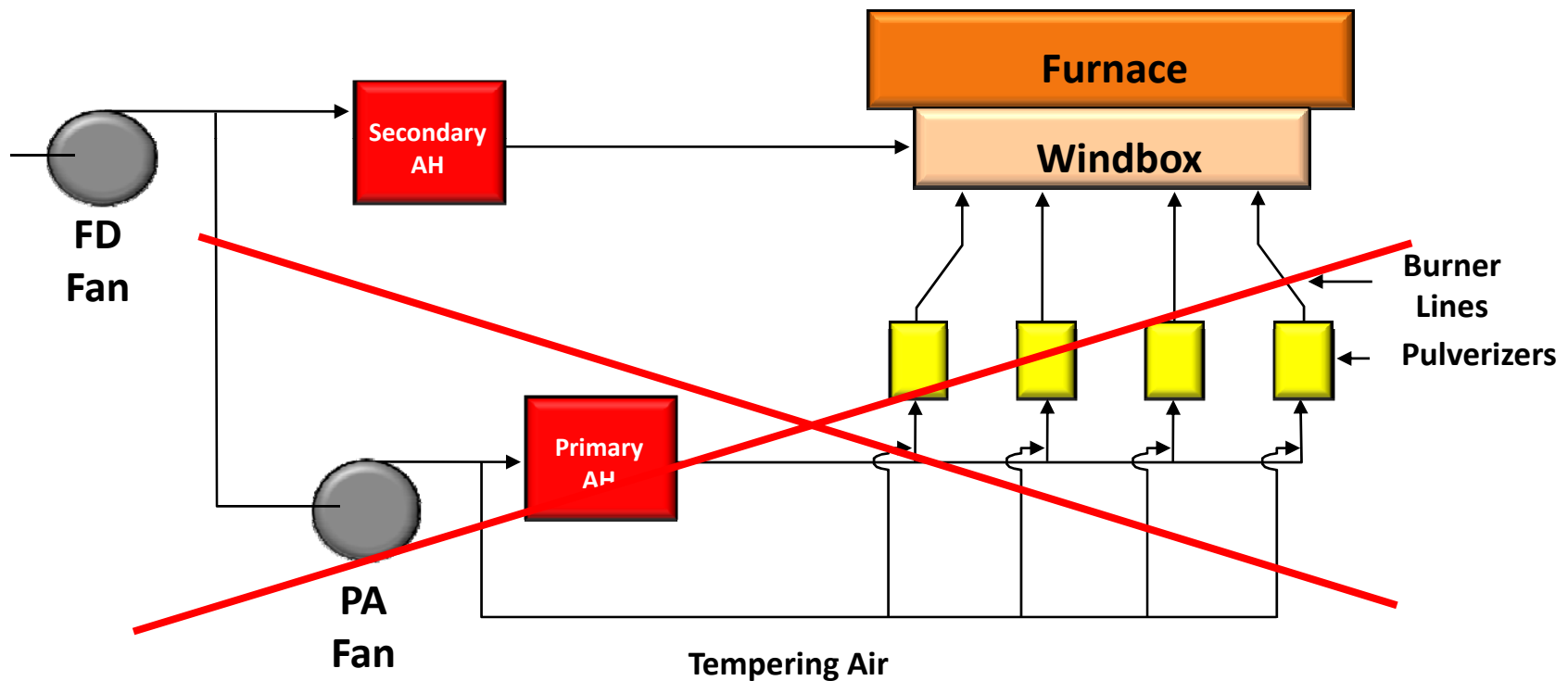

Coal to NG Conversion Air System Considerations

The FD Fan Capacity will need to be checked

- ▶ After a gas conversion, all combustion air must be delivered by the FD fan through the existing Secondary AH and Secondary Air ducts to the windbox and through the burners (and/or OFA system).

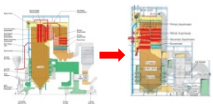

Coal to NG Conversion Air System Considerations

The FD Fan Capacity will need to be checked

- ▶ After a gas conversion, all combustion air must be delivered by the FD fan through the existing Secondary AH and Secondary Air ducts to the windbox and through the burners (and/or OFA system).
- ▶ FGR (if required) will exacerbate the FD fan issues

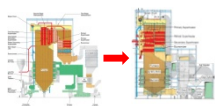

Coal to NG Conversion Air System Considerations

The FD Fan Capacity will need to be checked

- ▶ After a gas conversion, all combustion air must be delivered by the FD fan through the existing Secondary AH and Secondary Air ducts to the windbox and through the burners (and/or OFA system).
- ▶ FGR (if required) will exacerbate the FD fan issues
- ▶ The airheater performance should also be checked, especially if IFGR is used for NOx control

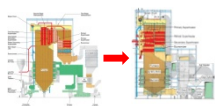

Coal to NG Conversion Burner Options

For coal fired boilers there are four approaches depending on the owner's objectives

1. Completely abandon coal – Replace all burners with new gas burners
2. Retain ability to fire coal – Coal nozzle replacement only with gas elements
3. Retain ability to fire coal – PC burners with gas elements
4. Continue to fire coal – Partial burner replacement/modification

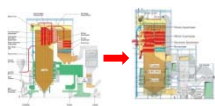
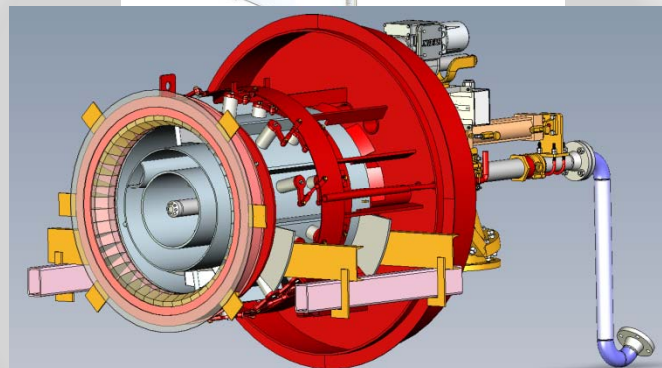
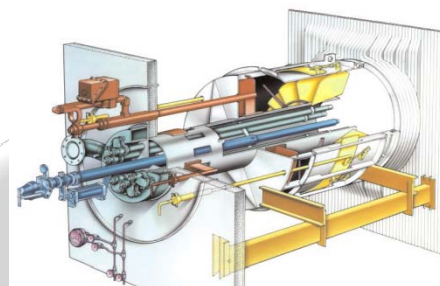

Coal to NG Conversion

Approach 1 – Abandon Coal – Complete Retrofit

- Complete Burner replacement with new gas only burners

Highest cost & longest outage time

Allows for best combustion and boiler performance

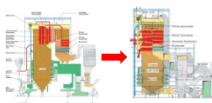
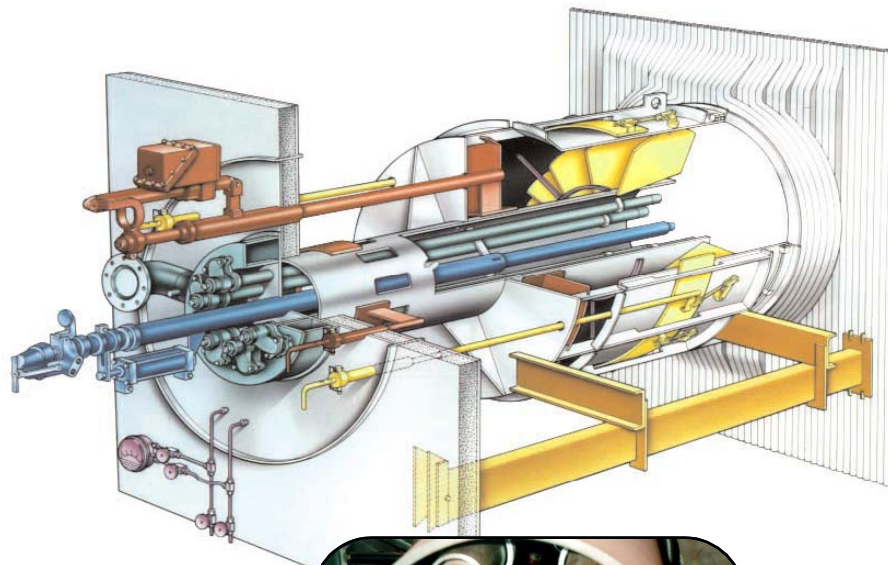

Coal to NG Conversion

Approach 2 – Retain Coal – Coal Nozzle Replacement

Where a unit is already equipped with PC burners, a replacement coal nozzle can be supplied incorporating a gas element

- Lower cost & shorter outage time
- Performance compromises
- Provides a hedge against gas curtailments & shortages

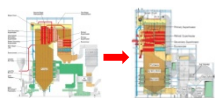
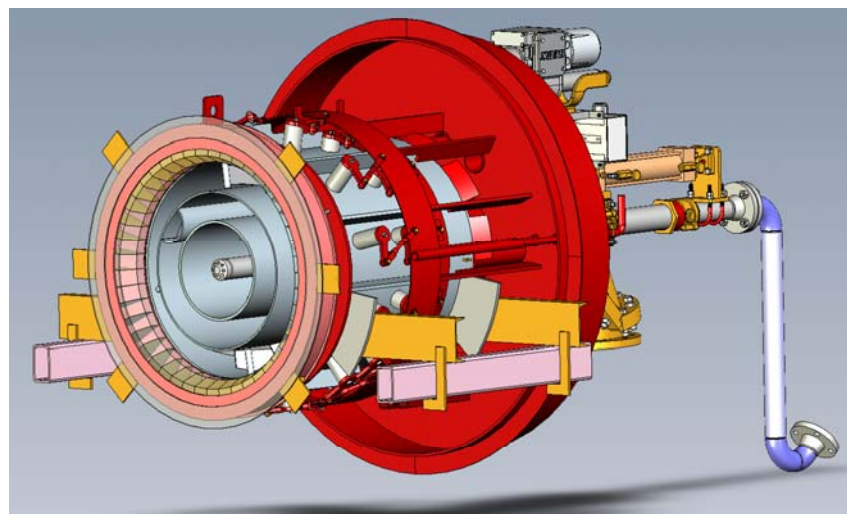

Coal to NG Conversion

Approach 3 – Retain Coal – Burner Replacement

Where existing burners are not suitable for a simple coal nozzle replacement, a complete PC burner with gas elements can replace existing burners

- Higher cost & longer outage time
- Allows for good compromise between fuel flexibility and combustion performance
- Burners can be sized for reasonable pressure drop and/or to accommodate FGR
- Provides hedge against gas curtailments & shortages

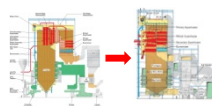
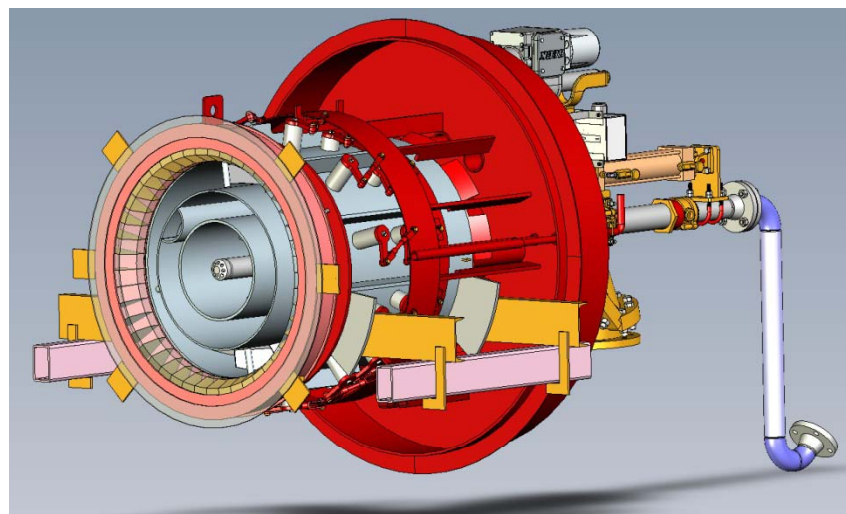

Coal to NG Conversion

Approach 4 – Retain Coal – Augment / Partial Replacement

In some cases where an owner plans to continue to fire coal but would like to augment with gas to lower emissions or improve turndown, some burners can be replaced or modified for gas firing

- More applicable to larger units ($\geq 250\text{MW}$)
- Good tool for turndown improvement
- Can be coupled with change to gas ignitors for incremental increase in heat input on gas

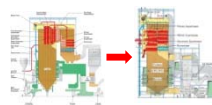
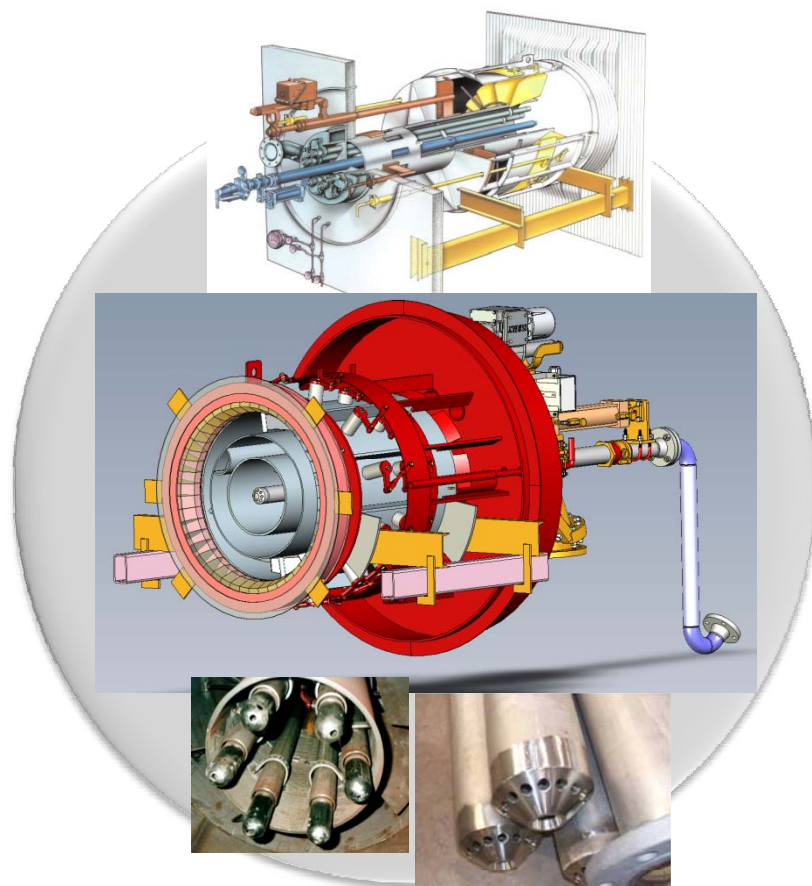

Corner Fired Retrofit

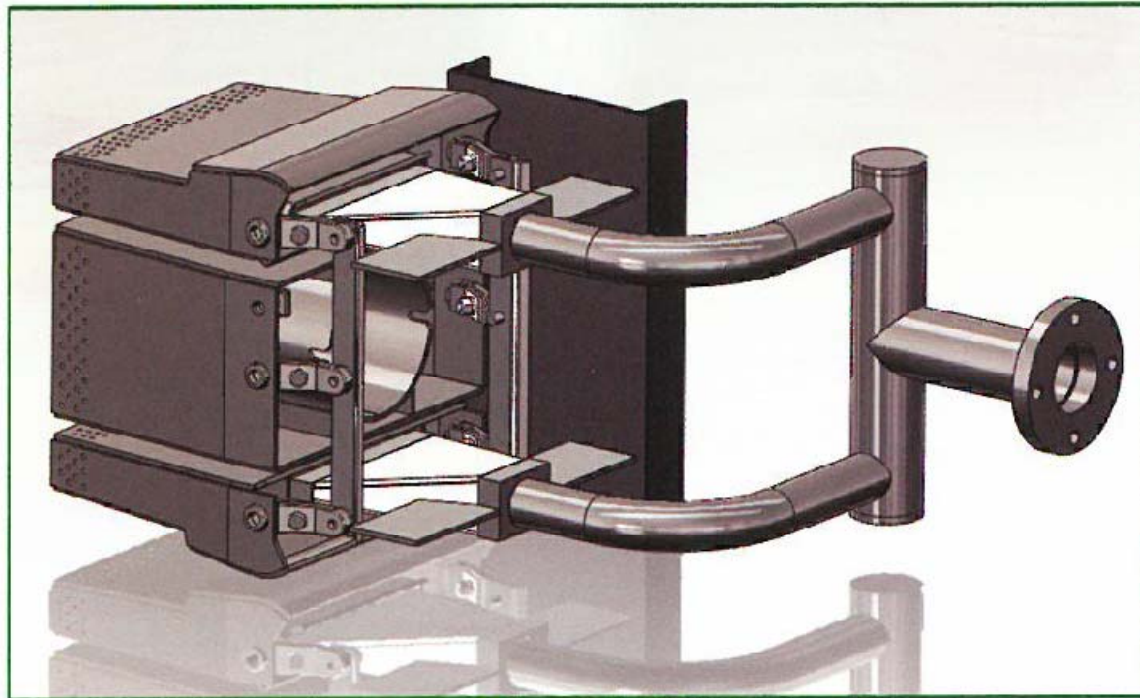

**Typical R-V gas compartment arrangement
with fixed gas spuds and tilting nozzle tips**

Coal to NG Conversion

NO_x Formation and Control

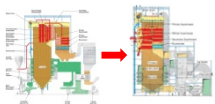
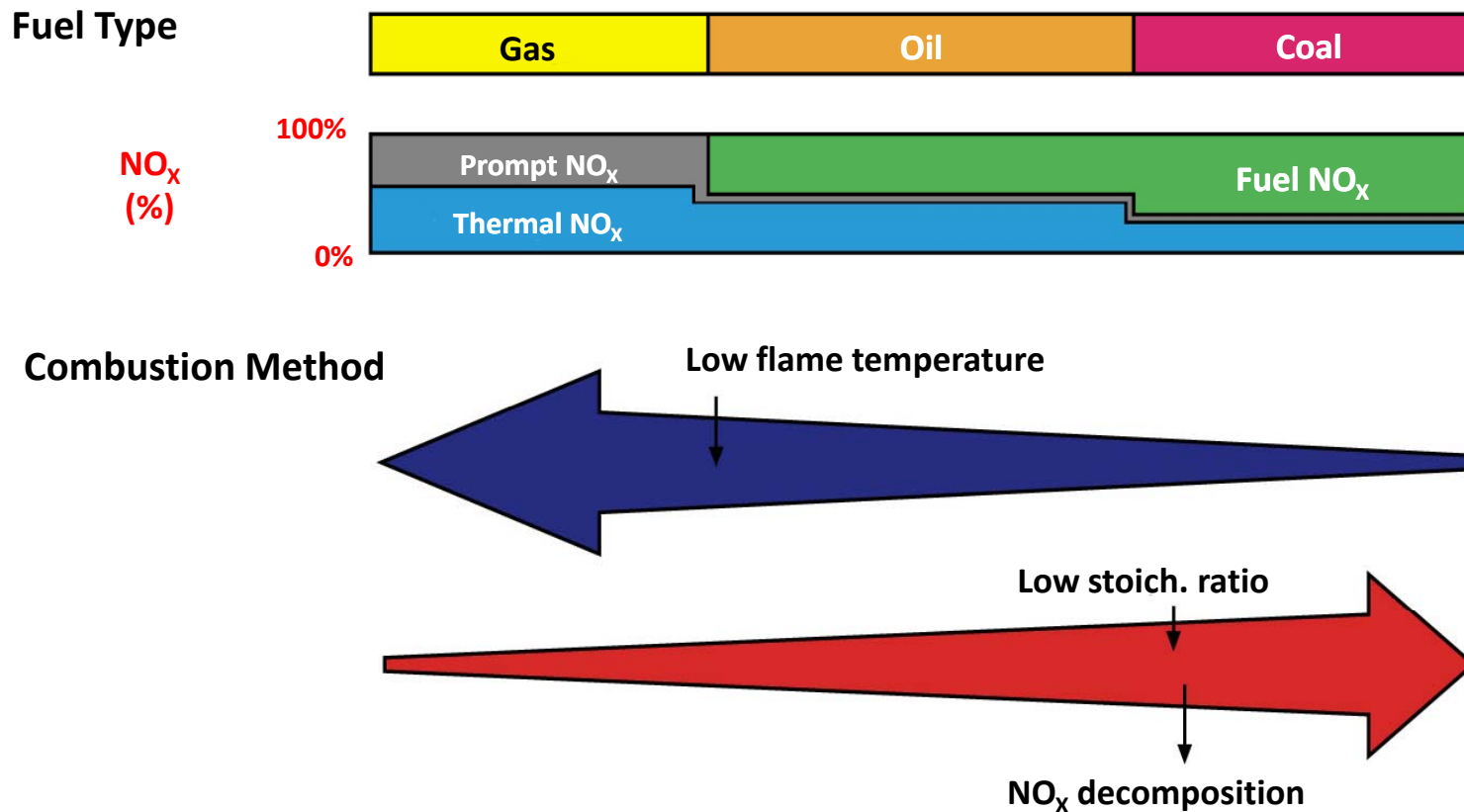

Coal to NG Conversion *NO_x Formation and Control*

Thermal NO_x

- ▶ Dissociation & oxidation of nitrogen from combustion air

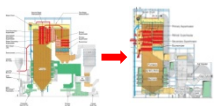

Coal to NG Conversion *NO_x Formation and Control*

Thermal NO_x

- ▶ Dissociation & oxidation of nitrogen from combustion air
- ▶ Exponentially dependent on temperature, threshold ~2800F

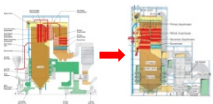

Coal to NG Conversion *NO_x Formation and Control*

Thermal NO_x

- ▶ Dissociation & oxidation of nitrogen from combustion air
- ▶ Exponentially dependent on temperature, threshold ~2800F
- ▶ Primary mechanism for NO_x formation from natural gas

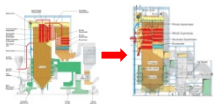

Coal to NG Conversion *NO_x Formation and Control*

Thermal NO_x Control Strategies

- Burner Zone release Rate

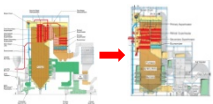

Coal to NG Conversion *NO_x Formation and Control*

Thermal NO_x Control Strategies

- ~~• Burner Zone release Rate~~

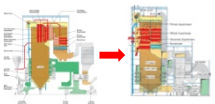

Coal to NG Conversion *NO_x Formation and Control*

Thermal NO_x Control Strategies

- ~~• Burner Zone release Rate~~
- Gas Recirculation to Windbox

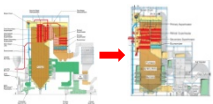

Coal to NG Conversion *NO_x Formation and Control*

Thermal NO_x Control Strategies

- ~~• Burner Zone release Rate~~
- Gas Recirculation to Windbox
- Staging

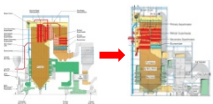

Coal to NG Conversion

Other Burner Scope Items:

- ▶ FGR or IFGR system – depending on NO_x performance level desired
- ▶ OFA system – depending on NO_x performance level desired
- ▶ Burner throat openings (not common)
- ▶ New ignitors

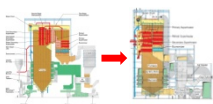
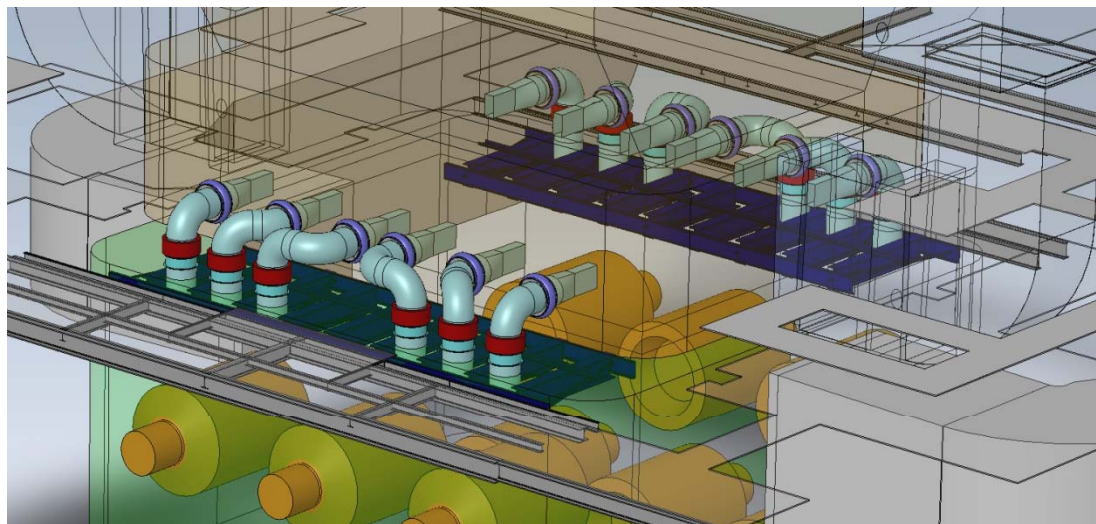

Gas Supply Considerations

1. NFPA
2. Main Gas Supply
3. Igniter Gas Header
4. Main Gas Header
5. Venting
6. Flame Scanning
7. Combustion Control



National Fire Protection Association

Within the Boiler House – NFPA 85

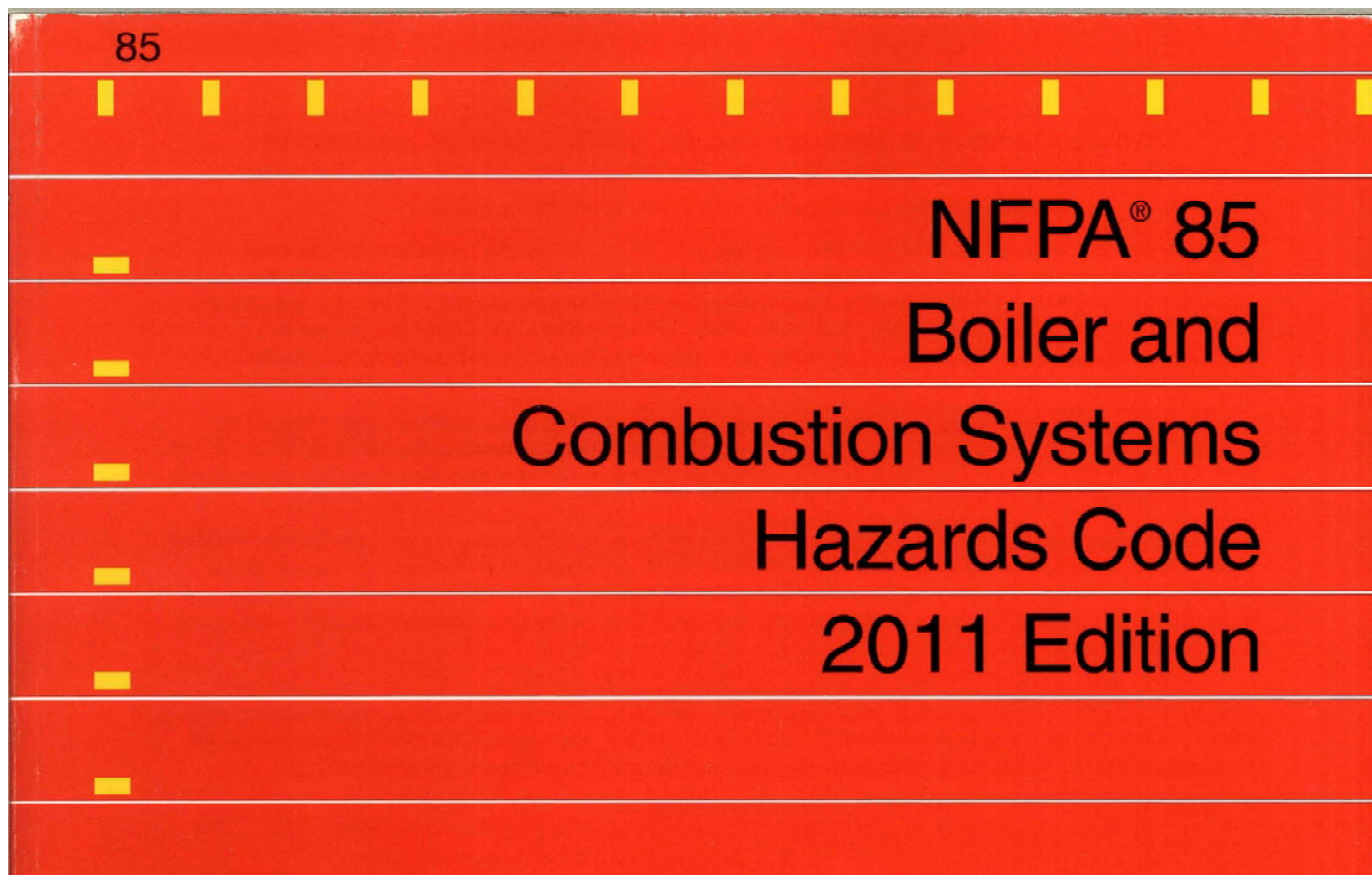

NFPA – Balance of Plant

1. Natural Gas Supply – NFPA 54 National Fuel Gas Code
2. Liquefied Natural Gas – NFPA 59A - Standard for the Production, Storage, and Handling of Liquefied Natural Gas. (LNG)

Potential use as a replacement for oil as an igniter fuel.

Main Gas Supply

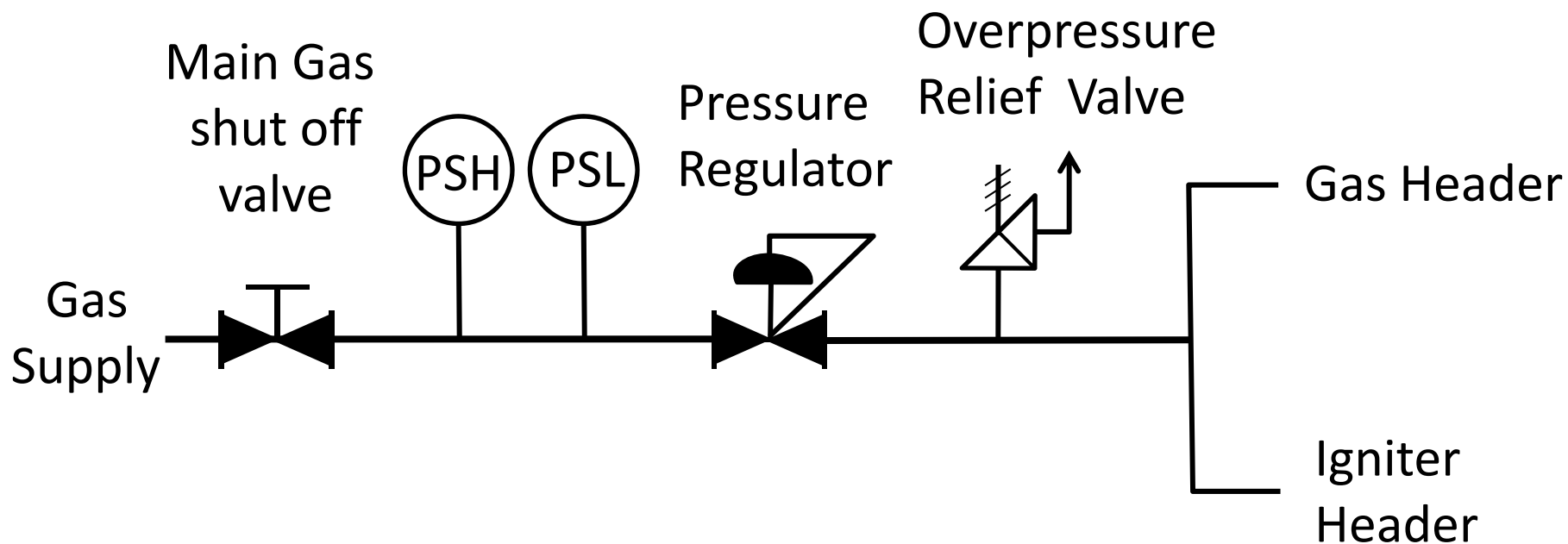

Igniter Gas Header

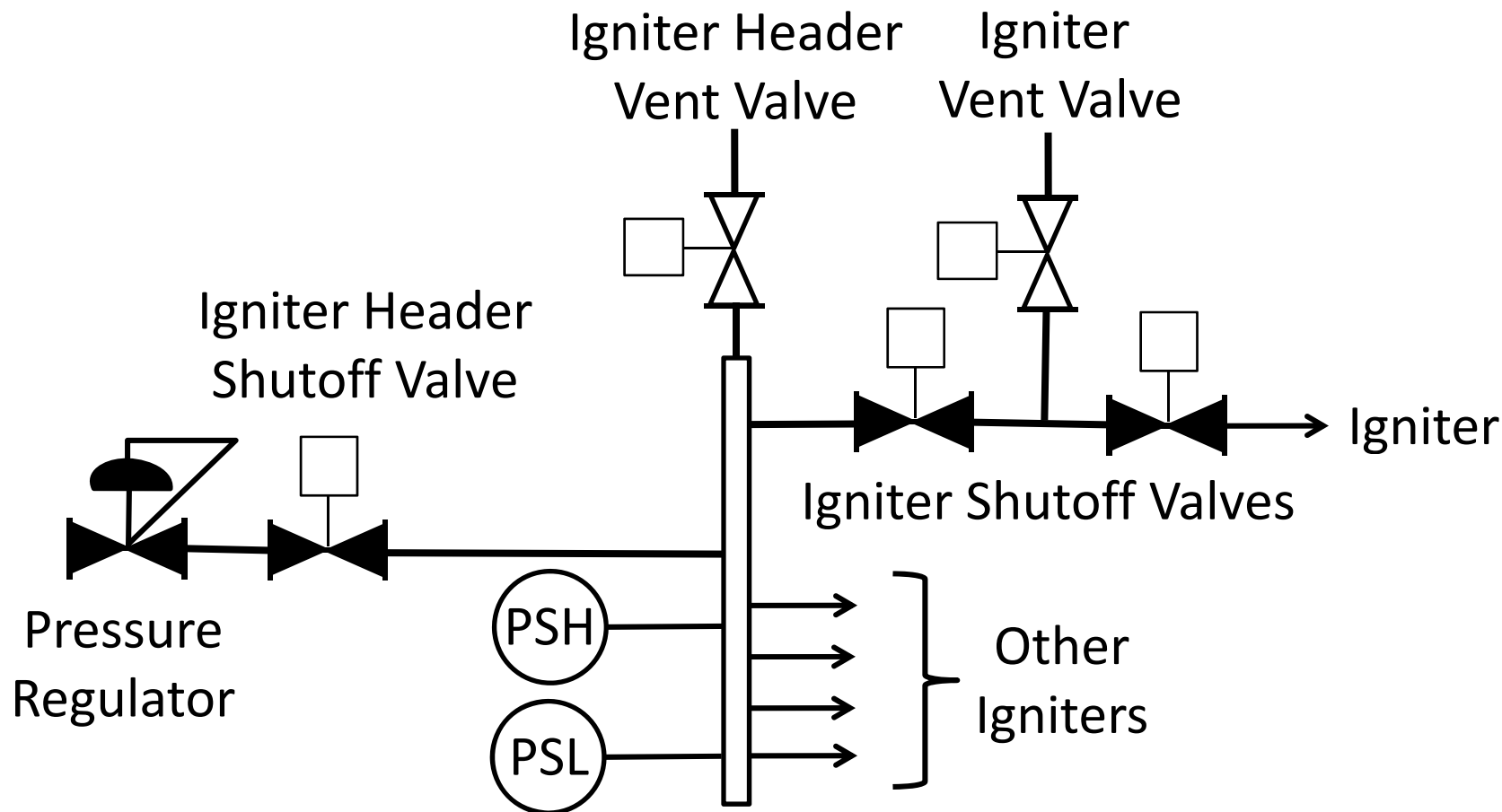

Leak Testing

- Chapter 6 of NFPA 85 describes the requirements for leak testing the gas supply system within the boiler house.
- These requirements include permanent provisions within the gas piping system for performing leak tests.
- Newer Burner Management systems include a leak test function within the start-up routines.

Burner Gas Header

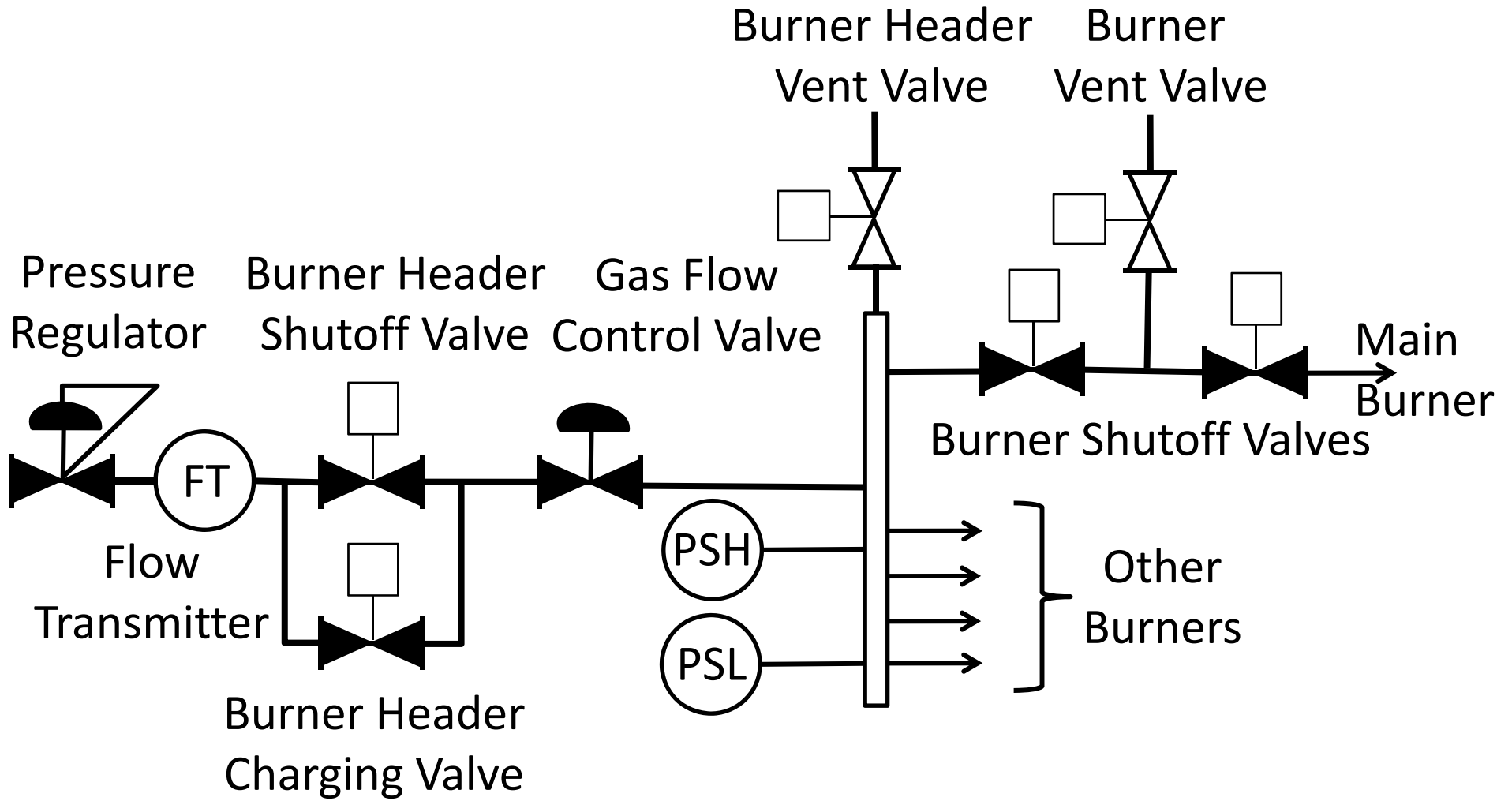

Venting

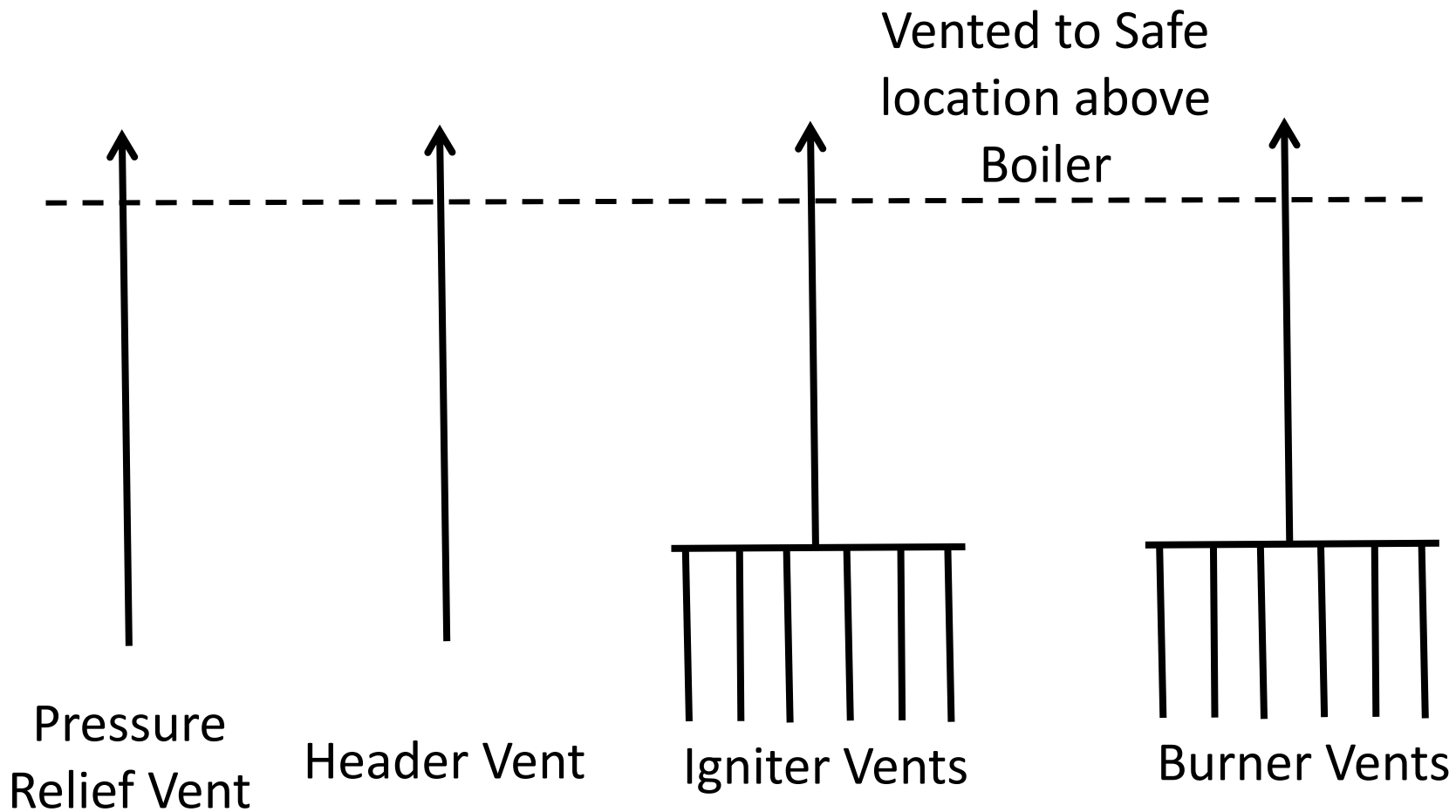

BMS Requirements

- ▶ No single component failure shall prevent a mandatory Master Fuel Trip (MFT)
- ▶ BMS logic system independent from any other logic system
- ▶ Logic protected from unauthorized changes
- ▶ Logic not to be changed on-line
- ▶ Proper operator intervention not to be prevented
- ▶ Trips require operator intervention to reset
- ▶ Signals from boiler control system permitted, but they must be hardwired if part of MFT

Master Fuel Trip (MFT)

Stop All fuel flow to furnace.

- ▶ Close all burner header safety shutoff valves
- ▶ Close igniter header safety shutoff valves
- ▶ Close individual igniter safety shutoff valves
- ▶ De-energize igniter sparks
- ▶ De-energize precipitators and other ignition sources

Flame Scanning - Gas

- Scanner types – Ultraviolet and Ionization
- Sighting to insure flame discrimination
- Gas Recirculation considerations

Flame Scanners – Gas Applications

Ultraviolet (UV)
Scanner Head



Ionization Detector



Combustion Control

1. Existing control strategy is usually sufficient
2. Increase number of burners in service as load increases
3. When co-firing with coal burners, gas is fired through burners that are not firing coal. Separation of fuels via pulverizer groups
4. Maintain burner pressure within specified range

Combustion Control

5. Air flow should always lead fuel flow
6. Fuel to Air curves should be based on BTU values for Gas.
7. Cross limiting of fuel to air
8. Boiler outlet Oxygen used for air trim control

Area Classification

- A gas conversion can be cause to review the Area Classification.
- NFPA 85 section 4.1.5 and A4.1.5 (Annex) references Hazardous Area Classifications.
- **However -**
- Addition of a Gas Supply to the boiler house **DOES NOT** automatically change the Area Classification to Hazardous.

Take Away Points

- Pressure Part Changes May Be Necessary
 - To restore steam temperatures
 - To reduce spray flows
 - To address metallurgy issues

Take Away Points

- Pressure Part Changes May Be Necessary
 - To restore steam temperatures
 - To reduce spray flows
 - To address metallurgy issues
- **FD Fan Capabilities Will Need to be Reviewed**

Take Away Points

- Pressure Part Changes May Be Necessary
 - To restore steam temperatures
 - To reduce spray flows
 - To address metallurgy issues
- FD Fan Capabilities Will Need to be Reviewed
- **There Are a Variety of Conversion Strategies**

Take Away Points

- Pressure Part Changes May Be Necessary
 - To restore steam temperatures
 - To reduce spray flows
 - To address metallurgy issues
- FD Fan Capabilities Will Need to be Reviewed
- There Are a Variety of Conversion Strategies
- **Conversion Will Involve a Substantial Amount of Gas Piping and Valves**

Take Away Points

- Pressure Part Changes May Be Necessary
 - To restore steam temperatures
 - To reduce spray flows
 - To address metallurgy issues
- FD Fan Capabilities Will Need to be Reviewed
- There Are a Variety of Conversion Strategies
- Conversion Will Involve a Substantial Amount of Gas Piping and Valves
- Introduction of Gas **DOES NOT** Automatically Re-Classify an Area

Take Away Points

- Pressure Part Changes May Be Necessary
 - To restore steam temperatures
 - To reduce spray flows
 - To address metallurgy issues
- FD Fan Capabilities Will Need to be Reviewed
- There Are a Variety of Conversion Strategies
- Conversion Will Involve a Substantial Amount of Gas Piping and Valves
- Introduction of Gas DOES NOT Automatically Re-Classify an Area
- **There Are No “Pat” Answers**

Take Away Points

- Pressure Part Changes May Be Necessary
 - To restore steam temperatures
 - To reduce spray flows
 - To address metallurgy issues
- FD Fan Capabilities Will Need to be Reviewed
- There Are a Variety of Conversion Strategies
- Conversion Will Involve a Substantial Amount of Gas Piping and Valves
- Introduction of Gas DOES NOT Automatically Re-Classify an Area

There Are No “Pat” Answers

Questions?

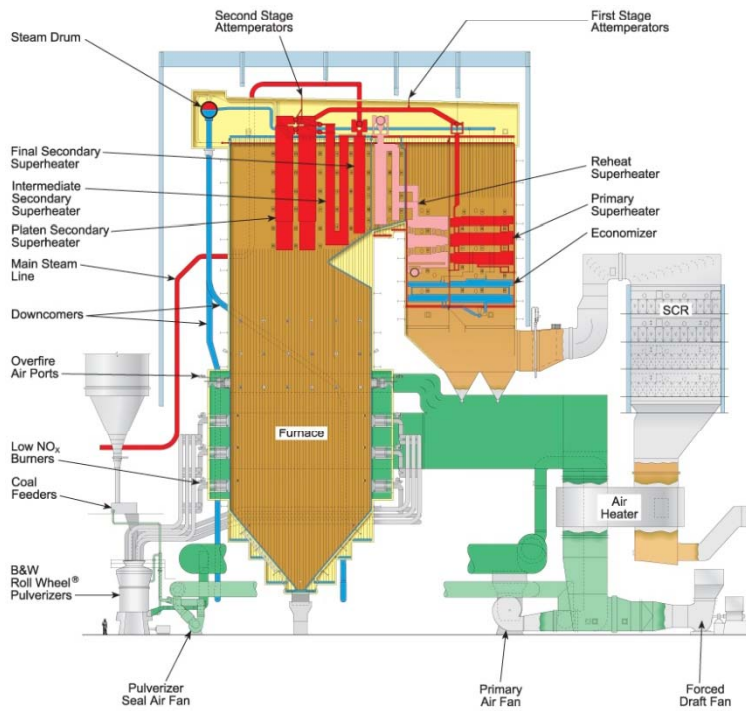

Typical PC Boiler

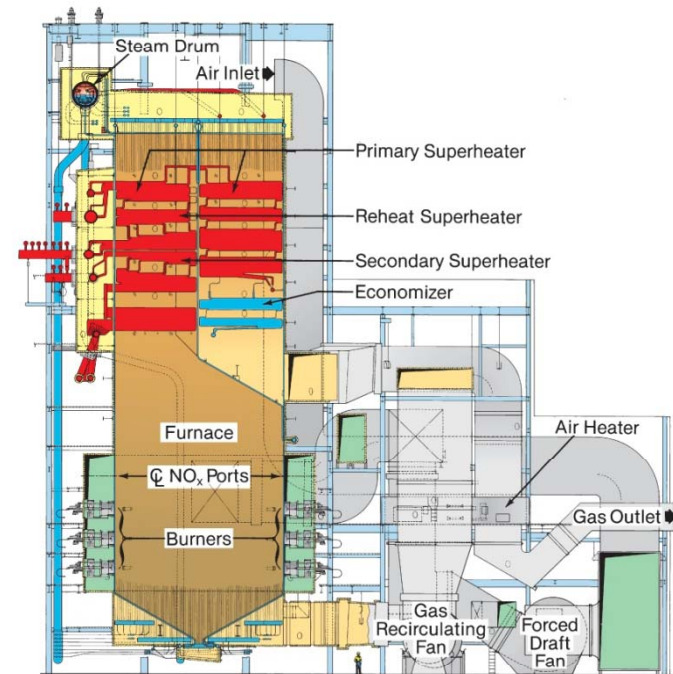

Typical Gas Boiler

Back-Up

3.3.85.1 Class 1 Igniter. An igniter that is applied to ignite the fuel input through the burner and to support ignition under any burner light-off or operating conditions. Its location and capacity are such that it will provide sufficient ignition energy, generally in excess of 10 percent of full load burner input, at its associated burner to raise any credible combination of burner inputs of both fuel and air above the minimum ignition temperature.

3.3.85.2 Class 2 Igniter. An igniter that is applied to ignite the fuel input through the burner under prescribed light-off conditions. It is also used to support ignition under low load or certain adverse operating conditions. The range of capacity of such igniters is generally 4 percent to 10 percent of full load burner fuel input.

3.3.85.3 Class 3 Igniter. A small igniter applied particularly to fuel gas and fuel oil burners to ignite the fuel input to the burner under prescribed light-off conditions. The capacity of such igniters generally does not exceed 4 percent of the full load burner fuel input.

3.3.85.4 Class 3 Special Igniter. A special Class 3 high energy electrical igniter capable of directly igniting the main burner fuel.